

Design and Construction of a Biogas Burner

David Olubiya Obada*, Anthony Iheanyichukwu Obi, Muhammad Dauda and Fatai Olukayode Anafi

Department of Mechanical Engineering, Ahmadu Bello University, Zaria, Nigeria.

* obadaavid4@gmail.com

Received 21 July, 2014, Accepted 14 September 2014, Published 23 September 2014

Abstract: This paper details the design and fabrication of a burner system, operating on biogas, for use in remote or rural regions of developing countries such as Nigeria. A desirable use for such a system in these areas is domestic cooking, and the burner has been designed with this need in mind, focusing on characteristics such as simplicity, cost effectiveness, efficiency and safety. Mild steel, brass and galvanized pipe sourced locally were selected for the construction. An empirical version of Bernoulli's theorem was used to derive the flow rate of gas. The different components of the burner design were shown. Also discussed are the modifications necessary to meet the requirements of stable flame for the burner and the testing involved in determining the performance of the burner system.

Keywords: Biogas, burner, efficiency, performance

Introduction

The rural energy problem in many developing countries like Nigeria has not changed in the last 20–30 years, and millions of people still lack enough energy inputs to sustain economic development (Stout and Best, 2001). Fossil energy, which is the main energy stay of Nigeria is estimated to be declining, a trend that will intensify after the year 2000 (Pimentel et al., 1998). This is because the world supply of oil is projected to last approximately 50 years at the current production rate, a projection that is based on current consumption rate and population.

Although biogas generation has been utilized since the 1950's, and the principles of digestion are well documented, little is known about the burning of such gases. This is due to the complex nature of methane, and difficulties associated with getting it to burn. In most cases, burners are developed using a 'trial-and-error' process, rather than consulting a text, or applying a formula. A gas burner generally is a device to generate a flame to heat up products using a gaseous fuel such as acetylene, natural gas or propane. Some burners have an air inlet to mix the fuel gas with air to make a complete combustion (Fulford, 1996). The main influencing factors in using biogas as a combustible gas are gas/air mixing rate, flame speed, ignition temperature and gas pressure.

Compared to liquefied petroleum gas, biogas needs less air per cubic metre for combustion. Therefore, gas jets are larger in diameter when using biogas. About 5.7 litres of air are required for total combustion of 1 litre of biogas, while for butane it is 30.9 litres and for propane 23.8 litres (Sasse et al., 1991). Smith (1994) concludes that biomass (the waste material that is used to produce biogas) is "the single most important source of energy" among developing countries, especially within the domestic sector. The main use for biomass is in household cooking, with wood representing the major energy source. The present use of wood is contributing to the serious problem of deforestation around the globe, forcing governments to seek cheap and available alternatives (Smith, 1994).

Biogas, an alternative fuel that is both sustainable and renewable is produced from anaerobic fermentation of organic material in digestion facilities (Anggono et al., 2012; 2013; Cacia et al., 2012). It does not contribute to the increase in atmospheric carbon dioxide concentrations because it comes from an organic source with a short carbon cycle and is a green solution in the development of sustainable fuels (Anggono et al., 2012; 2013). Furthermore, the digestion facilities can be constructed quickly in a few days using unskilled labor (Lichtman et al., 1996). Biogas contains 50–70% methane and 30–50% carbon dioxide, as well as small amounts of

Design and Construction of a Biogas Burner

other gases and typically has a calorific value of 21–24 MJ/m³ (Cacua et al., 2012; Ferrer et al., 2011; Bond et al., 2011). Based on chemical analysis, the composition of the biogas produced in East Java is 66.4% methane, 30.6% carbon dioxide and 3% nitrogen (Anggono et al., 2012;2013). Methane is a flammable gas, whereas, nitrogen and carbon dioxide are inhibitors (Ilminnafik et al., 2011). Various wastes have been utilized for biogas production and they include amongst others; animal wastes (Nwagboet al., 1991; Zuru et al.,1998; Alvarez et al., 2006), industrial wastes (Uzodinma et al., 2007), food processing wastes (Arvanitoyannis and Varzakas, 2008), plant residues (Ofoefule et al., 2008; 2009) etc. Many other wastes are still being researched on as potential feedstock for biogas production. Biogas is best used directly for cooking/heating, light or even absorption refrigeration rather than the complication and energy waste of trying to make electricity from biogas. Pumps and equipment can also run on a gas powered engine rather than using electricity (Fulford, 1996).

If combustion is perfect, the flame is dark blue and almost invisible in daylight. Stoves are normally designed to work with 75% primary air. If too little air is available, the gas does not burn fully and part of the gas escapes unused. If too much air is supplied, the flame cools off thus prolonging the working time and increasing the gas demand (Sasse et al., 1991).The 2-flame burners are the most popular type(Werner et al., 1989). There are several types of biogas stoves in use across the world. An example is the Peking stove that is widely used in China and the Jackwal stove widely used in Brazil. The Patel Ge 32 and Patel Ge 8 stoves are widely used in India, and the KIE burner is used in Kenya (Sasse,1988). The efficiency of using biogas is 55% in stoves, 24% in engines and 3% in lamps (Sasse et al., 1991).

Biogas technology amongst other processes (including thermal, pyrolysis, combustion and gasification) has in recent times also been viewed as a very good source of sustainable waste treatment /management, as disposal of wastes has become a major problem especially to the third world countries (Arvanitoyannis et al, 2007). The effluent of this process is a residue rich in essential inorganic elements like nitrogen and phosphorus needed for healthy plant growth known as bio fertilizer which when applied to the soil enriches it with no detrimental effects on the environment (Bhatet al, 2001).

Figure 1 shows a biogas combustion set up. The biogas has been compressed, just as it is obtainable in a liquefied natural gas set up.

This study therefore is geared towards the design and fabrication of a burner system, operating on biogas, the modifications necessary to meet the requirements of stable flame for the improvised burner and the testing involved in determining the performance of the burner system.

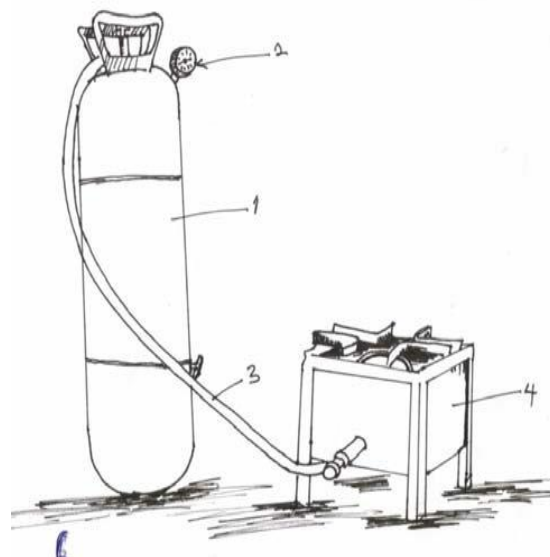

Figure 1: Biogas cylinder and Burner Configuration (1) Biogas cylinder (2) Pressure gauge (3) Rubber hose (4) Biogas burner (Ezekoye and Okeke, 2006).

Material and methods

Design considerations, theory and calculations

Design considerations

During the design of the biogas burner, the following factors were considered;

- Specific gravity of gas
- Calorific value
- Volume of biogas produced
- Composition of the gas produced
- Gas pressure
- Flame speed (velocity)

Design and Construction of a Biogas Burner

Main design parameters

For every design study, a few parameters are significant to ensure a proper fit of parts during assembly. It is important to note that the gas inlet pipe should be smooth and subsequently the determination of the following important dimensions

- Diameter of the jet (d_o)
- Length of the mixing pipe (L)
- Number and diameter of flame port holes (d_H)
- Height of the burner head. (H)

Description of the stove

The main components of the stove are the injector, the air/gas mixing chamber and the burner. The injector tapers into a nozzle of about 0.01mm^2 which enters into the air/gas mixing chamber. The air/gas mixing chamber opens into the burner head. The burner head has 32 jets each of 0.02m^3 from which the gas can be ignited. The air/gas chamber is held in position by two bracket welded to the frame. The combustion of biogas is regulated by moving the injector into and out of the air/gas chamber, which regulates the amount of air that enters the chamber. If the injector is moved deeper into the air/gas mixing chamber, the drift of oxygen into the burner is reduced thus reducing combustion. On the contrary, when the injector is moved out of the air/gas mixing chamber, more oxygen enters into the burner thereby increasing combustion. The frames and the stands are made from angle bars. A wall made from metal sheet welded round the frame serves as wind breaker. The stove is connected to the gas holding unit of the biogas plant by a rubber hose which convey biogas from the gas holder of the plant to the stove.

Design operation sequence

The following operation sequence was followed for the design of parts, process and the construction. These procedures include;

1. Selecting the biogas digester to evaluate the burner performance.
2. Obtain information on the maximum gas pressure obtainable in the digester selected.
3. Computing the parts sizes.
4. Producing the working diagrams
5. Selecting the materials for the parts.
6. Selecting manufacturing methods.
7. Fabrication, assembly and performance evaluation.
8. Comparative analysis.

9. Quality optimization (i.e efficiency assessment).
10. Finishing and commissioning.

Specific material selection

The following materials were chosen for this work;

1. Mild steel for the frame and burner ports because it can withstand high temperature applications, readily available and also ensures the robustness of the system.
2. Galvanized mild steel for throat because it has a fair resistance to corrosion, and for its manufactured shape(hollow).
3. Brass for the gas orifice because it's operating temperature will not be up to its melting point.

The biogas plant for the study was designed and fabricated by Muhammad (2011) and was selected for its good performance in generating gas. Design calculations for the burner were done and appropriate sizes of the parts chosen, fabricated and assembled. Two burners were produced, the second one being an improvement of the first. The improvised burner was tested for efficiency.

Design theory and calculations

Injector orifice

The amount of gas used by a burner is controlled by the size of the gas jet or injector orifice. This is usually a brass thimble with a hole drilled in the end screwed onto the end of the gas line fitting, so that it can be easily replaced (Fulford, 1996).

The gas flow rate (Q) is related to the gas velocity (V) by the area (A) of the pipe through which it is flowing

$$Q = VA \dots\dots\dots(1)$$

Gas flow through an injector orifice (jet)

An empirical version of Bernoulli's theorem was used to define the flow rate.

$$Q = 0.0467 C_d A_0 \sqrt{\frac{P}{S}} \dots\dots\dots(2)$$

- where Q = gas flow rate (m^3h^{-1})
A₀ = area of orifice (mm^2)
P = gas pressure before orifice (mbar)
S = specific gravity of gas
C_d = coefficient of discharge for the orifice

The coefficient of discharge for the orifice takes into account the vena contractor (A sudden change in

Design and Construction of a Biogas Burner

flow area) and friction losses through the orifice. It usually has a value between 0.85 and 0.95 (Fulford, 1996).

Throat size

The flow rate of the mixture in the throat (Q_m) is then given by:

$$Q_m = \frac{Q(1+r)}{3600} \dots\dots\dots(3)$$

With Q_m in m^3s^{-1} and Q in m^3h^{-1} (Fulford, 1996). From the composition of the gas, the stoichiometric air requirement is 5.5, then the entrainment ratio

$$= \frac{5.5}{2} = 2.75$$

The diameter of throat using Priggs' formula (Fulford, 1996) is

$$d_t = \left(\frac{r}{\sqrt{s}} + 1\right) d_0 \dots\dots\dots(4)$$

Biogas flow rate through injector using the equation below

From equation 2;

$$Q = 0.0467 C_d A_0 \sqrt{\frac{p}{s}}$$

Where

- $A_0 = 3.44mm^2$
- $P = 10m \text{ bar}$
- $S = 0.94$
- $C_d = 0.9$ (Fulford, 1996)

$$Q = 0.0467 \times 0.9 \times 3.44 \sqrt{\frac{10}{0.94}} = 0.471m^3/h$$

Still using $C_d = 0.9$ and gas supply pressure of 10m bar (Mahmuda, 2011) the injector size is

$$d_0 = \sqrt{\frac{Q}{0.036C_d}} \sqrt{\frac{s}{p}} \dots\dots\dots(5)$$

where S = specific gravity of gas which is 0.94

P = gas pressure before orifice (m bar) = 10

$$d_0 = \sqrt{\frac{0.471}{0.0324}} \sqrt{\frac{0.94}{10}} = 2.1mm$$

The velocity of gas in the orifice is:

$$V_0 = \frac{Q}{3.6 \times 10^{-3} A_0} = 37.8ms^{-1} \dots\dots\dots(6)$$

Throat design

From the analysis of biogas composition carried out, the stoichiometric air requirement of the gas is 5.5, then the entrainment ratio r should be

$$r = 5.5/2 = 2.7. \text{ (Fulford, 1996)}$$

Using Prigg's formula for calculating the diameter of the throat, Diameter of throat (d_t)

$$d_t = \left(\frac{r}{\sqrt{s}} + 1\right) d_0 = \left(\frac{2.75}{\sqrt{0.94}} + 1\right) \times 2.1 = 14mm$$

The throat area then becomes:

from Area = πr^2
 Diameter of throat = 14mm

$$d_t = 14mm \therefore r_t = 7mm$$

$$\therefore A = 3.142 \times 7^2$$

$$= 153.9mm^2$$

The air inlet ports must have an area similar to that of the throat.

The gas pressure in the throat can be calculated thus;

$$P_t = P_0 - \rho \frac{V_0^2}{2g} \left[1 - \left(\frac{d_0}{d_t}\right)^4\right]$$

$$= 10^5 - 1.0994 \frac{37.8^2}{2 \times 9.81} \left[1 - \left(\frac{2.1}{14}\right)^4\right] = 10^5 - 80 Pa$$

The mixture flow rate at optimum aeration is:

$$Q_m = \frac{Q(1+r)}{3600} = \frac{0.471(1+2.75)}{3600} = 4.91 \times 10^{-4} m^3 S^{-1}$$

The total burner port area can now be chosen:

$$A_p > \frac{Q_m}{0.25} > \frac{4.19 \times 10^{-4}}{0.25} > 0.00196m^2, \text{ say } 0.002m^2$$

Burner Port Design

Design and Construction of a Biogas Burner

Fulford (1996) and Itodo (2007) used 5mm and 2.5mm diameter of burner port holes respectively. However, it could be said that there arose a problem of flame lift. Using 2mm diameter holes to minimize the problem of flame lift, the total number required will be

$$n_p = \frac{4A_p}{\pi d_p^2} = \frac{4 \times 0.002}{\pi \times 0.002^2} = \frac{0.008}{1.2568 \times 10^{-5}} = 634$$

Using flame stabilization theory (Fulford1996), it should be possible to reduce this number of burner ports, by up to 1/20, 32 holes were arrived at. Mild steel was used with appropriate finishing. This is because, this part will be raised to a very high temperature during operation and high corrosion rate resulting from frequent water contact.

Performance evaluation of the stove

The performance evaluation was carried out by rice cooking and water boiling and this is as shown in **Tables 1** and **2**. The time taken for the various tasks was determined from a stop watch. Boiled water was determined by observing bubbling and steam rising from the boiling water while the cooked material was determined by pressing between two fingers and crushing. The quantity of rice used was determined by weighing using an electronic weighing device. One liter of water was used in the evaluation. Boiling of the water and the rice were replicated thrice. The time taken for all the 32 jets of the stove to burn was also determined using a stop watch. The cooking rate (C_r), biogas consumption rate and the efficiency of the stove (Sasse, 1988) were calculated using the equations 8 and 9 respectively.

$$C_r = \frac{\text{quantity of commodity (gorl)}}{T_{\text{in taken}}} \quad (7)$$

$$\eta = \frac{C_r}{Q} \times 100\% \quad (8)$$

Results and discussion

The following results were obtained after the development procedure. **Figure 2** shows a pictorial view of the prototype burner. The unstable flame observed could be as a result of the plentiful burner ports atop the burner system. This gave rise to a modification of the burner in terms of the number of ports, which led to a reduced number of burner ports, hence, a rather stable blue flame. The primary air opening as could be seen on **Figure 3** is responsible for a proper mix of oxygen and gas which

gives the stoichiometric air fuel ratio responsible for a near complete combustion. The amount of primary air added to the gas before the flame, varies depending on the design of burner, but is usually around 50% of the total air requirement. One volume of methane requires two volumes of oxygen, to give one volume of carbon dioxide and two volumes of steam. Since there is around 58% methane in biogas and 21% oxygen in air,

$$\frac{1}{0.58} = 1.72 \text{ volumes of biogas requires } \frac{2}{0.21} = 9.52 \text{ volumes of air, or;}$$

$$\frac{1}{1+5.53} = 0.153 = 15.3\% \text{ biogas in air (Stoichiometric air requirement)}$$



Figure 2: Pictorial view of the first developed burner



Figure 3: Throat Diagram showing primary Air source.

The amount of gas used by the burner is controlled by the size of the gas jet or injector orifice. This is usually a brass thimble with a hole drilled in the end, screwed onto the end of the gas line fitting, so that it can be easily replaced. As well as controlling the gas flow rate, the injector has the second important role of separating the burner from the gas supply. It should be impossible for a flame to enter the gas supply pipe.

Biogas will burn over a fairly narrow range of mixtures from 9 to 17% biogas in air. If the flame is too rich, has too much fuel, then it will burn badly and incompletely, giving carbon monoxide (which is

Design and Construction of a Biogas Burner

poisonous) and soot (carbon particles). Burners are usually run “slightly lean”, with a small excess of air, to avoid the danger of the flame becoming rich (Fulford, 1996).

Figures 4- 6 show the exploded view of the developed burner, burner ports design of the prototype burner and assembly drawing of the improvised burner. The exploded view shows the frame of the burner, the burner port head, the throat, the nozzle or orifice and the burner port seat. The burner port design of the prototype burner, by virtue of its plentiful ports, further explains why an unstable flame was observed when the burner was put to a performance test.

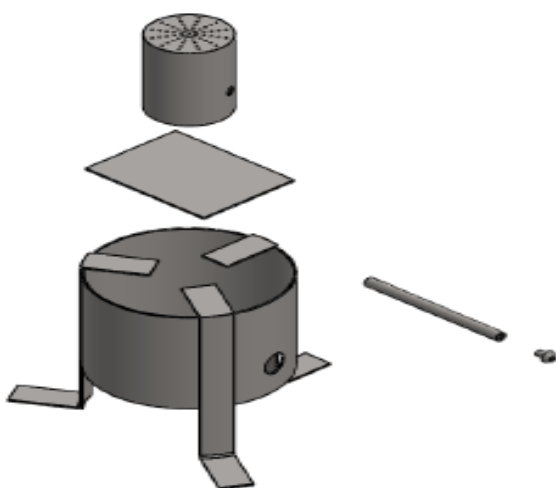

Figure 4: Exploded view of the developed burner



Figure 5: Burner ports design of prototype burner

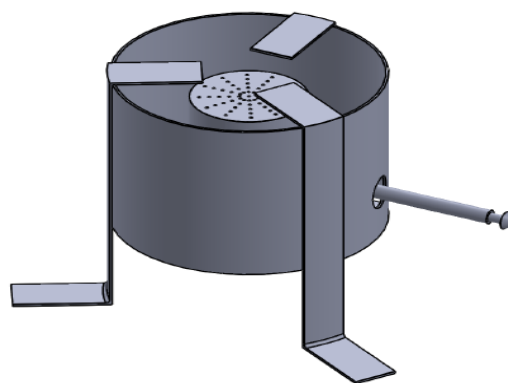

Figure 6: Assembly drawing of the improvised burner

Tables 1 and 2 are the summary of the performance of the biogas burner for boiling water and cooking rice. The table provides the cooking rate, biogas consumption rate and efficiency of the stove. The boiling rate was 0.10 l/min while the cooking rate was 1.74 g/min and for rice. The biogas consumption rates were 0.47 m³/min, and 2.87 m³/min for boiling water, and cooking rice. The corresponding efficiency of the burner was 21 and 60% for boiling water and cooking rice, respectively. The time taken for all the 32 jets of the improvised or modified burner to ignite was 1.10 and 1.40 seconds during water boiling and rice cooking respectively. The degree of boiling water was determined by observing bubbling and steaming while that for the rice cooking was determined by pressing a cooked sample between two fingers and crushing. This also played a major role in the biogas consumption rate as it determined the duration of the cooked material on the stove.

Table 1: Water boiling performance of improvised burner

Parameter	Observation Results					Mean
	1	2	3	4	5	
Qty of material(l)	1.0	1.0	1.0	1.0	1.0	1.0
Time taken (mins)	10.0	10.0	10.0	10.0	10.0	10.0
Time taken for all the 32jets to ignite (s)	1.5	1.0	1.0	1.0	1.0	1.0
Wind effect (no of time re-ignited)	Stable flame throughout the period					
Cooking rate (l/min, g/min)	0.1	0.1	0.1	0.1	0.1	0.1
Biogas consumption rate(m ³ /hr)	0.47	0.47	0.47	0.47	0.47	0.47
Efficiency of stove (%)	21.00					
Method of observation	Water bubbling and Steaming					

Design and Construction of a Biogas Burner

Table 2: Rice cooking performance of improvised burner

Parameter	Observation Results					Mean
	1	2	3	4	5	
Qty of material(l)	55.0	56.0	55.0	55.0	56.0	55.4
Time taken (mins)	32.0	32.0	31.0	33.0	32.0	32.0
Time taken for all the 32jets to ignite (s)	2.0	1.0	1.0	1.5	1.5	1.4
Wind effect (no of time re-ignited)	0	3	3	2	2	2
Cooking rate (l/min, g/min)	1.71	1.75	1.77	1.74	1.73	1.74
Biogas consumption rate(m ³ /hr)	2.87	2.87	2.87	2.87	2.87	2.87
Efficiency of stove (%)	60.00					
Method of observation	Pressed cooked sample in between two fingers and crush.					

Conclusion

The following conclusions are made from the successful fabrication of the stove;

- i. The stove boiled 0.10 liters of water in one minute while 1.73g of rice was cooked in a minute. The biogas consumption for water boiling and rice cooking were 0.47m³/min and 2.87m³/min respectively.
- ii. The efficiencies of the stove in the above processes were 21% and 60% respectively. The re-igniting of the stove resulting from the flame dying off may have been responsible for the comparatively low cooking and high biogas consumption rates.
- iii. The water boiling test result shows that the improved stove helps has a better biogas consumption rate compared to the prototype burner.

References

Anggono, W., Wardana, I.N.G., Lawes, M., Hughes, K.J., Wahyudi, S., Hamidi, N. (2012). Laminar Burning Characteristics of Biogas-Air Mixtures in Spark Ignited Premix Combustion. *Journal of Applied Sciences Research*;8:4126-32.

Anggono, W., Wardana, I.N.G., Lawes, M., Hughes, K.J., Wahyudi S., Hamidi N., and Hayakawa, A. (2013). Laminar Burning Velocity and Flammability Characteristics of Biogas-Air Mixtures

inSpark Ignited Premix Combustion. *Journal of Physics Conference Series*; 423:012015(1-7).

Arvanitoyannis, I.S., Kassaveti A. and Stefanatos, S. (2007). Current and potential uses of thermally treated olive oil waste. *Int. J. Food Sci. Tech.* 42 (7): 852-867.

Arvanitoyannis, I.S., and Varzakas, T.H. (2008). Vegetable Waste Treatment: Comparison and Critical Presentation of Methodologies. *Crit. Rev. Food Sci. Nut.* 48 (3): 205-247.

Bhat, P.R., Chanakya, H.N., and Ravindranat, N.H., (2001). Biogas plant dissemination. *Journal of Energy. Sustainable Development*, 1:39-41

Bond, T., Templeton, M.R. (2011). History and future of domestic biogas plants in the developing world. *Energy for Sustainable Development*;15(4): 347-54

Cacua, K., Amell, A., Cadavid, F. (2012). Effects of oxygen enriched air on the operation and performance of a diesel-biogas dual fuel engine. *Biomass and Bioenergy* ;45:159-167

Ezekoye, V.A., and Okeke, C.E. (2006). "Design, Construction, and Performance Evaluation of Plastic Biodigester and the Storage of Biogas". *Pacific Journal of Science and Technology.* 7(2):176-184.

Ferrer, I., Garfi, M., Uggetti E., Marti L.F., Calderon A. and Velo E. (2011). Biogas production in low-cost household digesters at the Peruvian Andes. *Biomass and Bioenergy*; 35:1688-74.

Fulford, D. (1988). "Running A Biogas Programme: A Handbook", Intermediate Technology Publication, UK,

Fulford, D. (1996). *Biogas Stove Design-A short course.* University of Reading, U.K.

Ilminnafik, N., Hamidi N. and Wardana, I.N.G. (2011). Behavior of flame propagation in LPG premixed combustion with carbon dioxide inhibitor. *International Journal of Academic Research*; 3(2):705-8.

Itodo, I.N., Agyo, G.E., and Yusuf, P. (2007). Performance evaluation of a biogas stove for cooking in Nigeria. *18th Journal of renewable energy South Africa*, p.1-5

Lichtman, R., Ellegard, A., Lal, S., Sharma, N. (1996). The Improved Biogas Systems Project: results and future work. *Energy for Sustainable Development*; 3(4):28-42.

Design and Construction of a Biogas Burner

- Muhammad, M. (2011). Design and Construction of 0.1m³ Batch Operated Portable Biogas Digester. M.Sc. Thesis, Ahmadu Bello University Zaria
- Nwagbo, E.E., Dioha, I.J., Gulma, M.A. (1991). Biogas from Cow and Donkey dung. *Nig. J. Solar Energy*. 10: 145 – 149.
- Ofoefule, A.U., and Uzodinma, E.O. (2008). Effect of Chemical and Biological treatment on Pre-decayed field grass (*Panicum Maximum*) for biogas production. *Niger. J. Solar Energy*. 19: 57 – 62.
- Ofoefule, A.U., Uzodinma, E.O. and Onukwuli, O.D. (2009). Methods on biogas yields from water hyacinth (*Eichhorniacrassipes*). *Int. J. Phy. Sci*. 4(8): 535-539.
- Pimentel, D., Pimentel, M., and Karpenstein-Mahan, O. (1999). Energy use in agriculture. Invited overview. Vol. 1, December.
- Sasse, L., (1988). *Biogas Plants*. 2nd edition. Vieweg and Sohn, Germany.
- Sasse, L., Kellner, C., and Kimaro, A. (1991). Improved Biogas Unit for Developing Countries. Vieweg and Sohn, Germany.
- Smith, E.H. (1994). "Mechanical Engineer's Reference Book", 12th Edition, Butterworth Heinemann Ltd, Oxford, UK,
- Stout, B. A., and Best, G. (2001). Effective energy use and climate change: Needs of rural areas in developing countries. Invited overview. Vol. III.
- Uzodinma, E.O., Ofoefule A.U., Eze J.I. and Onwuka N.D. (2007). Biogas Production from blends of Agro-industrial wastes. *Trends Appl. Sci. Res*. 2 (6): 554-558.
- Werner, U., Stohr, U., and Hoes N. (1989). *Biogas Plants in Animal Husbandries. A Practical Guide*. Vieweg and Sohn, Germany.